



Heavy Duty Refrigeration Compressors



Energy Efficient, Robust, Reliable

Technical Highlights Of Colt Compressors

2, 3, 4, 6, 9 and 12 Cylinder Series the leading technology with displacement from 106.16 to 1592.4 m³/h

Applicable for : R22, NH₃ (Ammonia)

Discharge Valve Assembly

- Three Concentric discharge valve rings ensure ample gas at flow passage at low lifting height ensuring less number of breakdowns.
- The use of sinusoidal spring made of Sandvik Steel, Sweden together with precision machined and lapped surface result in a trouble -free operation for a remarkable long time.
- Minimum inventory for spares since most parts are identical throughout the CT-Series Compressors.

Cylinder Liner

- Interchangeable cylinder liners are made of fine-grained, centrifugally cast, alloy iron.
- Fine boring and honing results in a mirror smooth running surface.

Suction Valve

- A hydro-mechanical suction valve lifting mechanism on each individual cylinder achieves loading and unloading.
- For unloading, the suction valve ring is lifted from its seat in the cylinder collar by spring tension. Admitting controlled oil pressure to the control piston, allows the suction valve ring to descend on its seat effects loading of the cylinder.

Easy Cleaning

- Suction gas strainer is another example of easy maintenance. Inside gauze strainer element can be easily removed.

Lubrication System & Filter

- Forced lubrication by a gear pump, driven directly by the crankshaft.
- The pump incorporates a differential pressure regulator to provide separate pressures for two oil systems: lubrication system and control oil system (Loading and Unloading).
- Automatically operating hydraulic delay valve ensures complete unloaded start.
- A metal gauze suction filter element and a throwaway discharge paper filter cartridges are provided for excellent filtering capacity of the lubricating oil with rare earth magnet ensure trouble free long running life.
- Oil return flow is visible with built-in Sight Glass.



Crankshaft

- Bearing surfaces of the high quality nodular cast iron crankshaft are ground to fine tolerances.
- Each crankshaft is dynamically balanced together with the counter weights resulting in smooth vibration free running.

Main Bearings

Main bearings are white metal lined steel backed bushes, pressed into the cast iron bearing covers. Intermediate bearing blocks are provided with spit type bearing shell of the same type.

Safety Pressure Spring

- Is ensured by built-in arrangement of buffer spring which protects compressor from incidental liquid hammer.

Easy & Quick Maintenance

- As piston/connecting rod assembly can be removed without removing the cylinder liner.
- Parts subjected to wear are easily accessible through large service doors with minimum special tools.
- Large water jacket around the cylinder with flange type covers are provided for easy cleaning and descaling avoids gas cutting and acid cleaning.
- Service covers are large in size.
- Gas tightness and impact proof.
- Smooth internal surfaces and chemical cleaning process guarantee the good oil condition during operation.

Piston

- Perfect sealing and low oil consumption due to 3 compression and 2-oil scrapper rings on each aluminum alloy piston thus minimizing oil carryover through discharge gas line.

Connecting Rod Assembly

- The forged steel connecting rod is drilled through for pressure lubrication of the piston pin.
- Steel backed white metal shells on big end and Needle Roller Bearing on small end of connecting rod.
- The complete piston & connecting rod assembly can be removed from the top for servicing without withdrawing the cylinder liner which makes it easy for maintenance.

Welded Steel Crankcase

- Rapid heat dissipation
- Gas tightness and impact proof
- Smooth internal surfaces with chemical cleaning process guarantee the good oil condition.

Quality adaptable to varying operating conditions

- Each cylinder is equipped with a hydraulically operated valve lifting mechanism giving absolutely capable capacity control and 100% unloading.

Painting

- With special epoxy primer and Polyurethane (PU) paint preceded by shot blasting and chemical treatment process ensure long life & corrosion protection. Powder coating is optional if demanded.

Electrical Panel

- Ensure safe running of the compressor
- Maximum safety with failure detection LEDs display.
- Pressure gauges and cut-outs are secured in metallic panel.
- Toggle switch for operation of solenoid valve.
- Hour meter used as a reference for running time of compressor for regular maintenance.
- Aesthetically attractive operation panel

Head Cooling*

- To keep the discharge temperature low.
- To increase the life of compressors.

* Only Head Cool Versions



Performance Data at 1000 R.P.M. | Capacity is at 5°C useful Super Heat
Single Stage Compressors

Compressor Model	Evaporating Temp. in °C	Condensing Temperature					
		20° C		30° C		40° C	
		Qo	Pe	Qo	Pe	Qo	Pe
CT 2	5	247900	39.2	226500	46.9	204300	55.3
	0	207900	37.6	189000	44.9	169500	52.7
	-10	142200	34.3	127600	40.5	112500	46.6
	-20	92800	30.6	81600	35.2	69900	38.7
CT 3	5	371900	57.8	339700	69.3	306400	82.0
	0	311800	55.4	283500	66.3	254200	78.0
	-10	213300	50.5	191500	59.8	168800	69.0
	-20	139200	45.0	122400	51.7	104900	57.1
CT 4	5	495900	76.4	453000	91.7	408600	108.6
	0	415800	73.2	378000	87.7	339000	103.4
	-10	284400	66.7	255300	79.0	225100	91.3
	-20	185700	59.3	163200	68.3	139900	75.4
CT 6	5	743900	113.5	679500	136.5	612900	161.8
	0	623700	108.7	567100	130.5	508500	154.0
	-10	426700	98.9	383000	117.4	337700	135.8
	-20	278500	87.8	244800	101.4	209900	112.1
CT 9	5	1115900	169.1	1019300	203.7	919400	241.7
	0	935600	162.0	850700	194.7	762800	229.9
	-10	640000	147.3	574500	175.1	506600	202.7
	-20	417800	130.7	367200	151.0	314900	167.1
CT 12	5	1487900	224.8	1359100	270.8	1225800	321.6
	0	1247500	215.3	1134200	258.9	1017000	305.8
	-10	853400	195.7	766000	232.7	675500	269.5
	-20	557100	173.6	489600	200.6	419800	222.0

Notes:

Qo= Cooling Capacity in Kcal/hr.

Pe= Power Required at Compressor Shaft in Kw.

Power Consumption and Capacities are proportional to the speed.

Interpolation of ratings is permissible.

For any condition outside the range given above please contact Saarthak Refrigeration.

Conversion factors:

1 Watt = 0.86 kcal/h

1 Watt = 3.41Btu/h

1kW = 1.36PS

Tons = Watt / 3518.6

1 kcal/h = 11.63 Watt

1 Btu/h = 0.293 Watt

1PS = 0.739kW

Performance Data at 1000 R.P.M. | Capacity is at 5°C useful Super Heat

Double Stage Compressors

Compressor Model	Evaporating Temp. in °C	Condensing Temperature					
		20° C		30° C		40° C	
		Qo	Pe	Qo	Pe	Qo	Pe
CT 21	-25	81100	36.8	75000	40.9	68700	45.5
	-35	52800	29.8	48700	33.3	44400	37.0
	-45	33000	24.0	30200	26.6	27400	29.3
	-55	19500	18.8	17800	20.4	16000	21.8
CT 31	-25	-	-	-	-	-	-
	-35	75600	42.1	69600	46.3	63500	50.9
	-45	47100	32.9	43200	36.3	39100	40.0
	-55	27900	25.4	25400	27.9	22800	30.3
CT 42	-25	162200	71.5	150000	79.6	137400	88.8
	-35	105700	57.5	97400	64.4	88900	71.9
	-45	66000	45.8	60500	51.1	54900	56.4
	-55	39100	35.6	35600	38.8	32000	41.4
CT 51	-35	-	-	-	-	-	-
	-45	71400	51.1	65300	55.2	59100	59.7
	-55	42100	37.7	38300	41.0	34300	44.4
CT 63	5	243300	106.1	225000	118.4	206200	132.1
	0	158500	85.2	146100	95.6	133300	106.7
	-10	99000	67.7	90800	75.6	82400	83.6
	-20	58700	52.3	53500	57.1	48100	61.1
CT 72	-25	-	-	-	-	-	-
	-35	172300	95.4	158700	104.1	144600	114.0
	-45	107400	72.5	98400	79.9	89100	88.0
	-55	63600	55.0	57900	60.5	51900	66.1
CT 93	-25	-	-	-	-	-	-
	-35	226900	122.1	209000	134.6	190500	148.5
	-45	141400	94.3	129600	104.6	117500	115.6
	-55	83800	72.0	76300	79.4	68600	86.6
CT 102	-35	-	-	-	-	-	-
	-45	142800	100.0	130700	108.2	118200	117.4
	-55	84300	73.4	76600	80.0	68700	86.8

Technical Data

For Single Stage Compressors

Compressor Model		CT 2	CT 3	CT 4	CT 6	CT 9	CT 12
Cylinder Arrangement		1XV	1XW	2XV	2XW	3XW	4XW
Number of Cylinders		2	3	4	6	9	12
Cylinder Bore	mm	160	160	160	160	160	160
Piston Stroke	mm	110	110	110	110	110	110
Permissible speed	Belt Drive from 400 to 1000 rpm in steps of 50						
Swept Volume at 1000rpm	m3/hr	265.4	398.1	530.8	796.2	1194.3	1592.4
Direction of Rotation	Anti-Clockwise looking from flywheel end						
Maximum Discharge Pressure	bar	21	21	21	21	21	21
Oil Charge Capacity	L	9	10	12	13	20	32
Cooling Water Flow for each Cylinder Jacket	8 LPM/Cyl at water inlet temp. 30°C., 15 LPM/Cyl at water inlet temp 40°C.						
Weight of Compressor (Without Flywheel)	kg	435	535	665	900	1245	1585
Moment of Inertia GD2 of crank mechanism	kg.m2	0.356	0.422	0.446	0.594	0.829	1.045
Ice Making Capacity* with Ammonia (Tonnes/day)	TPD	17.5	26.1	34.8	52.2	78.4	104.3
Power Consumption	kW	39.6	58.2	76.0	111.7	166.0	223.0

For Two Stage Compressors

Compressor Model		CT 21	CT 31	CT 42	CT 51	CT 63	CT 72	CT 93	CT 102
Cylinder Arrangement		1XW	2XV	2XW	2XW	3XW	3XW	4XW	4XW
Number of Cylinders-LP		2	3	4	5	6	7	9	10
Number of Cylinders-HP		1	1	2	1	3	2	3	2
Cylinder Bore-LP	mm	160	160	160	160	160	160	160	160
Cylinder Bore-HP	mm	160	160	160	160	160	160	160	160
Piston Stroke LP/HP	mm	110	110	110	110	110	110	110	110
Permissible speed	Belt Drive from 400 to 1000 rpm in steps of 50								
Swept Volume (LP CYL) at 1000rpm	m3/hr	265.4	398.1	530.8	663.5	796.2	928.9	1194.3	1327.0
Direction of Rotation	Anti-Clockwise looking from flywheel end								
Maximum Discharge Pressure	bar	21	21	21	21	21	21	21	21
Oil Charge Capacity	L	10	12	13	13	20	20	32	32
Cooling Water Flow from each Cylinder Jacket	8 LPM/Cyl at water inlet temp. 30°C.1, 5 LPM/Cyl at water inlet temp 4 0°C.								
Weight of Compressor (Without Flywheel)	kg	535	665	900	900	1245	1245	1585	1585
Moment of Inertia GD2 of crank mechanism	kg.m2	0.422	0.446	0.594	0.594	0.829	0.829	1.045	1.045

Typical Dimensions

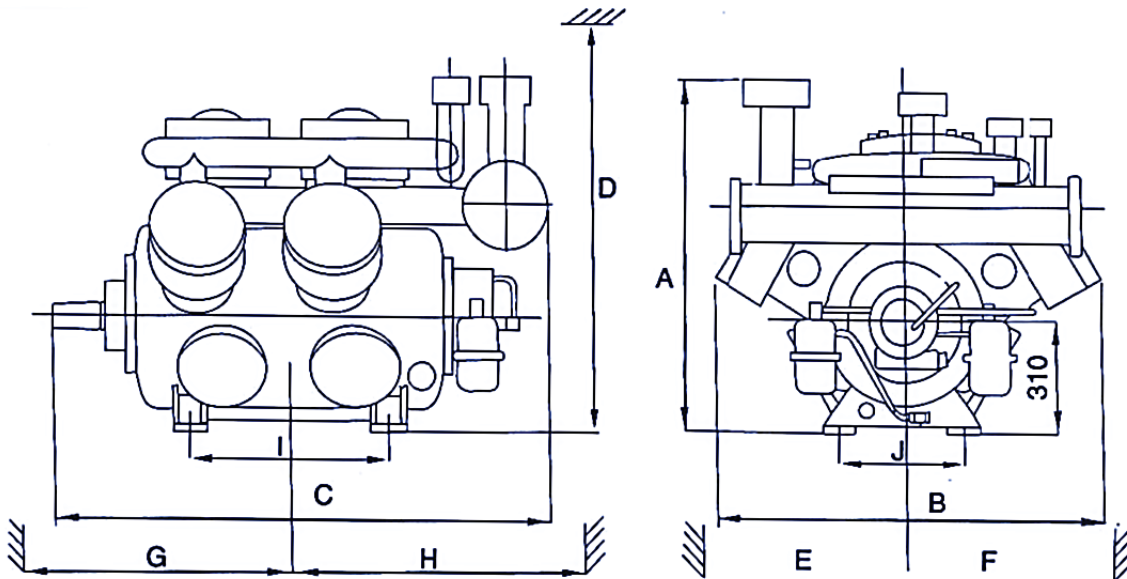

Type/ Dimension mm	CT 1	CT 2	CT 3/21	CT 4/31	CT 6/42/51	CT 9/63/72	CT 12/84/93/102
A	955	1000	1000	1000	1020	1020	1020
B	680	1030	1120	1030	1120	1120	1120
C	802	970	970	1170	1500	1861	2251
D	1085	1150	1150	1150	1170	1170	1170
E	500	600	725	600	725	725	725
F	900	1080	1080	1080	1280	1280	1280
G	1045	1045	1045	1344	1629	2238	2823
H	1045	1045	1045	1344	1629	2238	2823
I	140	215	215	380	570	960	1350
J	360	360	360	360	360	360	360



Saarthak Refrigeration Colt Compressor Series are most suitable for industrial refrigeration and low Temperature Applications such as Cold Storage, Ice Plants, Fisheries Plants, Ice Cream Plants, Dairy Plants, beverage making plants Chemical Plants, Pharmaceutical Plants, Vanaspati Plant & Air Conditioning Plants etc.

Saarthak Refrigeration range of open type compressors are available in single as well in double stage versions with use on Ammonia (NH₃) and R-22 Refrigerant etc. They are well-designed and robust machines capable of running continuously, for prolonged period with minimum attention. These compressors by virtue of their high speed and multiplicity of cylinder exceptionally compact and economical of space. These machines are also designed to accommodate varying refrigeration demands with maximum economy in power and are well suited to automatic installations.

Saarthak Refrigeration has a countrywide 'Sales & Service Network' for upkeep of every compressor it manufactures and every refrigeration package it builds. The international Customers in the Middle East, South East Asia and African Subcontinent has resulted in customer satisfaction abroad through trouble free operation of COLT compressors.

Our commitment to quality & reliability offers products to the customers that give the best value for money.

Saarthak refrigeration has developed the required infrastructure to support all its manufacturing processes. We have an in-house testing lab, CNC machining centers, stress relieving furnaces, testing facilities and Paint shops. With decades of experience and reliable performance of our compressors across the country, we have earned the trust of many customers. We are now leading amongst the leaders in the manufacture of reciprocating open type refrigeration compressors.

Manufactured by:



Authorized Distributors: